

J. PIAT.

SLIDE-RESTS FOR METAL-TURNING LATHES.

No. 172,480.

Patented Jan. 18, 1876.

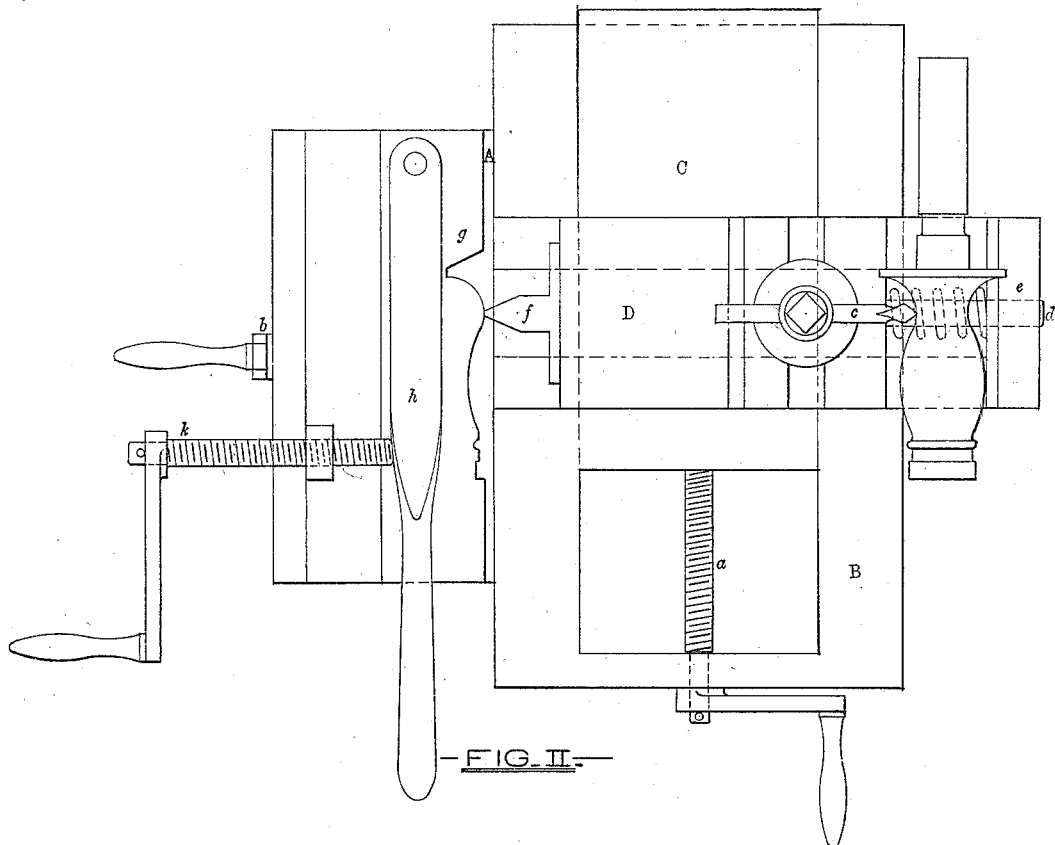
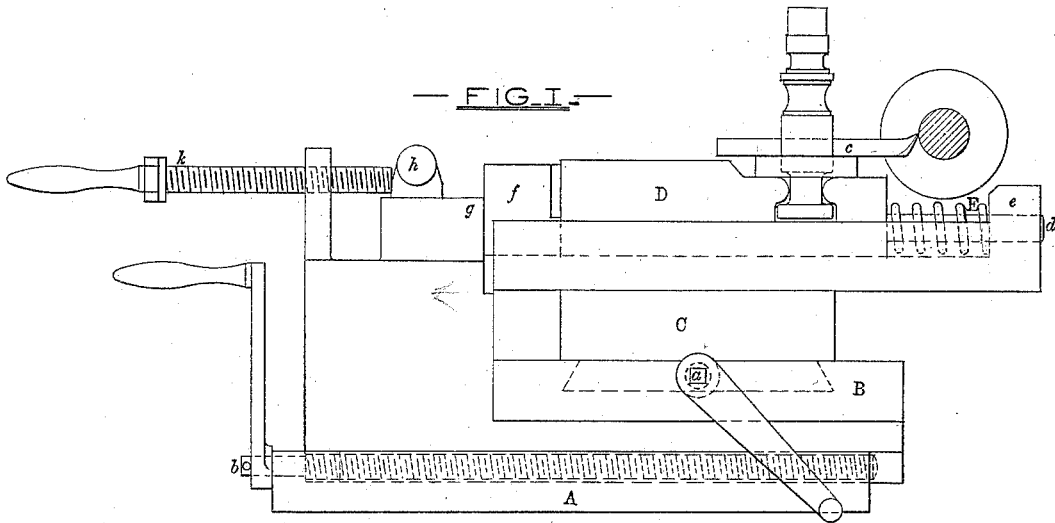

— WITNESSES —

Wm. W. Leonard
W. W. Wharton

— INVENTOR —

Joseph Piat,
by G. W. Howard,
his Atty.

UNITED STATES PATENT OFFICE.

JOSEPH PIAT, OF BALTIMORE, MARYLAND.

IMPROVEMENT IN SLIDE-RESTS FOR METAL-TURNING LATHES.

Specification forming part of Letters Patent No. **172,480**, dated January 18, 1876; application filed May 17, 1875.

To all whom it may concern:

Be it known that I, JOSEPH PIAT, of the city of Baltimore and State of Maryland, have invented certain new and useful Improvements in Slide-Rests for Turning-Lathes, of which the following is a specification; and I do hereby declare that in the same is contained a full, clear, and exact description of my said invention, reference being had to the accompanying drawing, and to the letters of reference marked thereon.

My invention relates to slide-rests, in which a pattern or former and a lever are used to govern the motion of the tool toward and from the work during its longitudinal movement, the cutting-edge describing a line corresponding to the contour of the pattern or former, and the lever being used to throw the tool forward to cut acute angles, or cut off the article being turned.

In the description of my invention which follows, due reference must be had to the accompanying drawing, forming a part of this specification, and in which—

Figure 1 is a side view of my improved slide-rest, partly in section, showing the relative positions of the tool and the article in process of turning; and Fig. 2, a plan of the same.

Similar letters of reference indicate similar parts in both figures.

A is the base-plate of the slide-rest, and B the slide, upon which the tool-support C D moves longitudinally of the lathe-shears when actuated by means of the screw *a*. The slide B, with the tool-support and attachments, is moved laterally of the shears aforesaid, and upon the base-plate A, by means of the screw *b*, to give the desired general diameter to the article to be turned, the motion necessary to form the said article to the required shape being accomplished by means herein-after described. The upper part D of the slide-rest is provided with the usual mechanism for holding the tool *c*, and is susceptible of lateral motion independently of that before alluded to by means of the following

parts: E is a spiral spring, confined upon a stem, *d*, between a projection, *e*, on the lower portion C of the tool-support, and the inner face of the upper portion D of the same. The spring E serves to force the part D back and bring a bolt, *f*, into contact with the edge of the pattern *g*, secured to a projection of the slide B.

In moving the tool and tool-support longitudinally of the slide, the bolt *f*, being at all times in contact with the pattern, by reason of the resiliency of the spiral spring E, describes a line, the shape of which corresponds with that of the pattern, and gives a similar form to the article turned through the medium of the tool.

When it is required to cut at such an angle that the bolt *f* cannot slide over the pattern, or when it is desired to cut the article off, the tool may be forced toward the work independently of the pattern by means of the lever *h*, operated by hand, or through the agency of a screw, *k*.

From the foregoing description, it will be understood that, after a pattern of a desired shape has been secured to the projecting portion of the slide B, and the tool fastened to the support C D, articles having shapes corresponding with that of the pattern may be rapidly turned without the aid of skilled labor, as the only manipulation necessary to give complete uniformity to the said articles is the regulation of their general diameters by means of the screw *b*.

Having thus described my invention, what I claim as new, and desire to secure by Letters Patent of the United States, is—

In a slide-rest for lathes, the combination of the slide B, tool-support C D, spiral spring E, bolt *f*, pattern *g*, and lever *h*, constructed and operating substantially as and for the purpose set forth.

JOSEPH PIAT.

Witnesses:

GEORGE TSCHUELIN,
W. W. WHARTON.